

## REMOVING AND INSTALLING MODULES

Remove and install modules and instruments when the equipment is due for calibration, or whenever other indications exist that the equipment may not be operating properly.

### VXI Mainframe Modules

The following removal and installation procedure applies to the modules located inside the VXI mainframe:

◆	Radisys EPC7 Computer	Slots 0-2
◆	Wavetek 1391 Pulse Generator	Slot 3
◆	HP E1426A 500 MHz Digitizing Oscilloscope	Slots 4-5
◆	Tektronix VX4801 Isolated Digital I/O Module	Slot 6
◆	Racal Dana 1260-35 96 Channel MUX	Slot 7
◆	HP E1411B VXI Digital Multimeter (Quantity 2)	Slots 8, 9
◆	Tektronix VX4356 20 Channel DPDT Switch Module	Slot 10
◆	NH Research 81201 Electronic Load	Slot 11
◆	HP E1328A 4 Channel D/A Converter	Slot 12

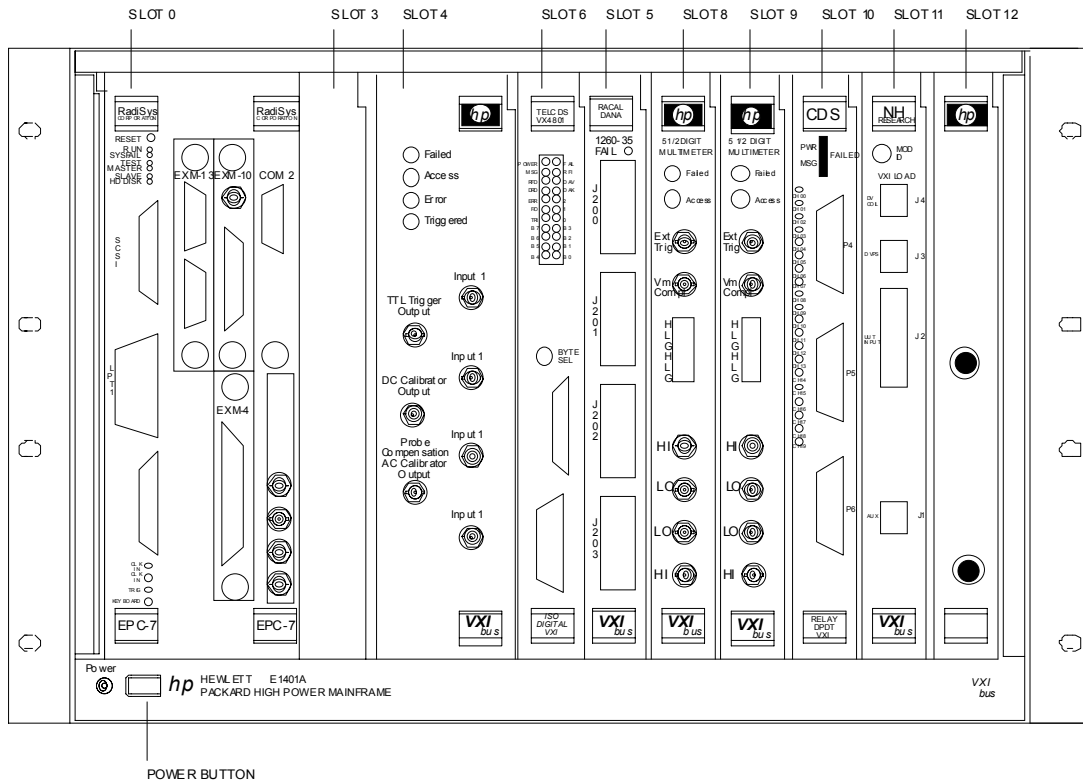

Figure 6-3. VXI Modules

### Equipment Required

- ◆ Small flat-blade screwdriver
- ◆ ESD static wrist strap, heel straps or shoes
- ◆ Anti-static bag or other ESD container

### B-Size Modules

All B-size modules are mounted in a B-to-C size adapter (HPE1403A or equivalent) as shown in the following figure:

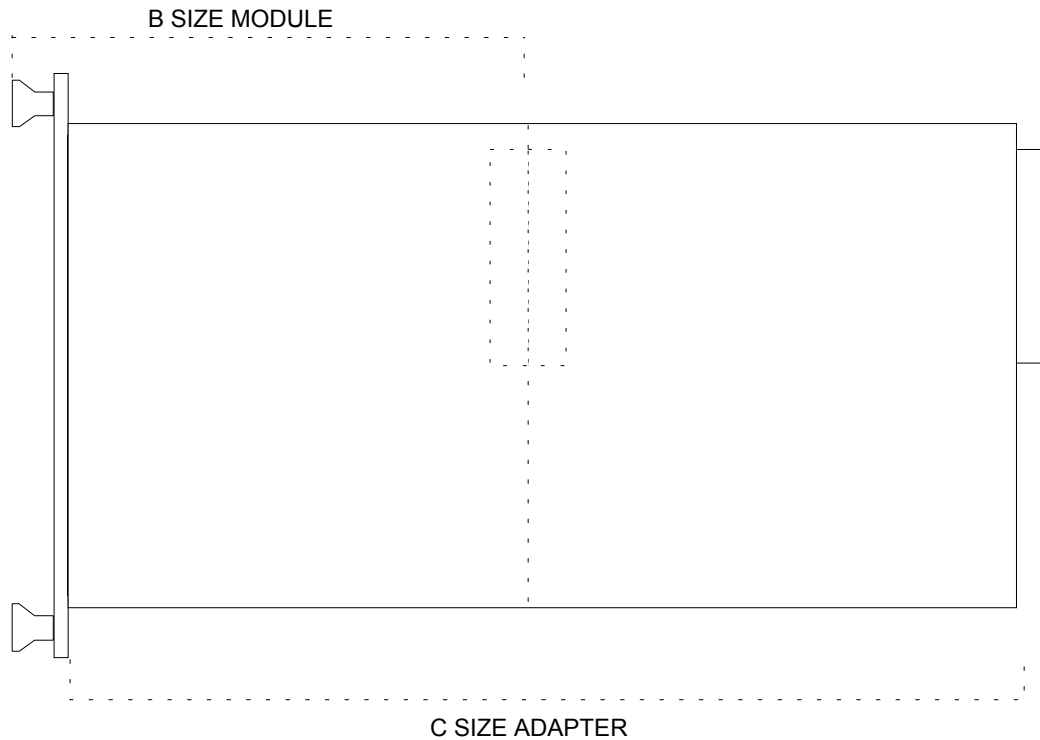

**Figure 6-4. B-Size VXI Module**

To remove the module:

1. Power down the tester as described in "Power Down" in "Chapter 2 - Operation."
2. Remove any cables attached to the front of the module. If they are not labeled, label them first to make installation easier.
3. Loosen the retaining screws at the top and bottom.
4. Pull on the handles located at the top and bottom  
Unlike C-size modules, B-size modules often do not have ejection-style handles. The module will generally come loose from the adapter, leaving the adapter in the mainframe.
5. The adapter must be removed in two cases:
  - a) If it is suspected of being bad, or
  - b) No replacement module will occupy it.
6. To remove the adapter, grip it inside the void left by the module and pull.  
In some instances it may be necessary to remove adjoining modules.

## C-Size Modules

To remove the modules, do the following:

1. Power down the tester as described in "Power Down" in "Chapter 2 - Operation."

2. Open the tester cabinet rear door.
3. Attach your ESD strap to the metal cabinet frame or otherwise verify you are at the same potential as the equipment.
4. Disconnect all cabling from the module to be removed.



**NOTE**

Make a note where the cables were connected for ease of re-connection later.

---

5. Loosen the mounting screws located on the extreme top and bottom of the module.
6. Unseat the module using the ejector tabs located on the extreme top and bottom of the module.
7. Slide the module out of the VXI rack and into an ESD safe container taking care not to damage or disconnect any of the adjacent wiring.



**NOTE**

To prevent ESD damage to the module, avoid touching any module connectors or components when the module is removed from the VXI mainframe.

---

## Installing the Modules

To install the modules, do the following:

1. Verify all of the configuration dip switches on the replacement module are configured exactly like the switches on the module previously removed. This information should be noted on a label on each module.
2. Slide the module into the VXI rack making sure the guides located on the top and bottom of the module are seated in the tracks inside the VXI rack.  
Take care not to damage or disconnect any of the adjacent wiring.
3. Gently apply pressure to the ejector tabs until the module is seated in the VXI rack. Do not force the module into the rack as this may damage the connectors. If the module will not seat in the VXI rack remove it and try again.
4. Tighten the mounting screws located on the extreme top and bottom of the module.
5. Reconnect all cables to the replacement module.
6. Close the cabinet door.
7. Power up the tester as described in "Power Up" in "Chapter 2 - Operation."